

FlexTop HRT Universal Transmitter

4...20 mA transmitter with HART® communication.

RTD, T/C, mV and R inputs

Isolation voltage 3.75 kV_{ac}

Configuration via FlexProgrammer or HART® configurator

Accuracy < 0.1°C (Pt100)

Configurable linearisation, damping and status indication

Current-trim and sensor-trim

Local, remote or fixed compensation for "cold junction" (CJC)

Ex approvals:

Demko EEx ia IIC T5/T6, ATEX II 1G

BKI Ex ia IIC T5/T6

Barbara Ex ia IIC T5/T6

Demko Ex N IIC T5/T6

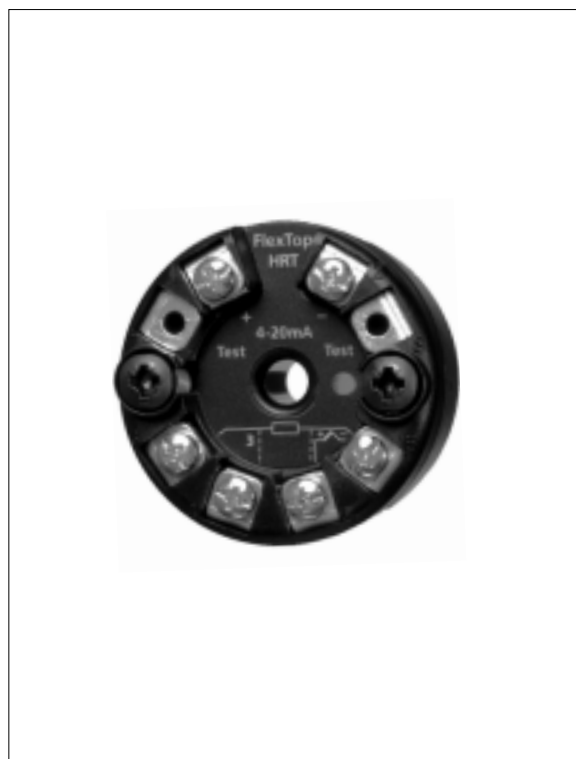

Description

FlexTop HRT is a 4...20 mA loop-powered, configurable universal transmitter with galvanic isolation between input and output. The input can be configured for RTD or T/C sensors, resistance, current or voltage signals.

Either 2-, 3- or 4-wire connection can be selected for the resistance input. The built-in temperature sensor or a remote Pt100 sensor can be used to compensate for "cold junction" (CJC) if thermocouples are connected.

The HART® communication feature on-line process calibration and adjustment, transmitter configuration and multiple process control in 2-wire networks.

The configuration can be established from a standard HART® configurator or the dedicated FlexProgrammer configuring tool connected to a PC.

FlexTop HRT is embedded in silicone which makes it resistant to humid environments.

FlexTop HRT has a 6 mm center hole for fast sensor replacement and spring loaded mounting screws which ensure a safe fastening even in vibrating environments.



Bourdon-Haenni A/S
 Jacob Knudsens Vej 14
 DK-8230 Aabyhøj, Denmark
 Tel: +45 89 31 76 11
 Fax: +45 86 25 65 77
 E-mail: info@bourdon-haenni.dk
 Web: www.bourdon-haenni.com

Technical Data

Input

Digital accuracy	See „Measuring ranges“
CJC-compensation	Local < 0.5°C Remote < 0.2°C
RTD measuring current	0.2 mA, continuously
Cable resistance (3-/4-wire)	T > 600°C: Max. 10 Ohm/wire {1} T < 600°C: Max. 30 Ohm/wire {1}
Protection	+/- 35 V _{dc}
Suppression	50 and 60 Hz
Resolution	16 bit
Repeatability	< 0.05°C

Output

Signal span	4...20 mA, 2-wire {1} 20...4 mA, 2-wire {1}
Accuracy	< 0.1% of signal span
Supply range	12...35 V _{dc}
Ripple immunity	3 V _{rms}
Load equation	$R_L \leq (V_{cc} - 12)/23$ [kOhm]
Up/Down scaling limits	23 mA/3.5 mA {1}
Damping	0...15 sec. {1}
Response time (t₉₀)	Pt100 1.0 sec. ; T/C 1.6 sec.
Resolution	12 bit

HART® data

Protocol	HCF standard, Rev.5
Features ¹⁾	Read serial number Read/Change user ID Read/Change configuration Read input signal value Read output signal value Input signal logging 2-point sensor-trim 2-point current-trim

Environmental conditions

Operating temperature	-40...85°C
Humidity	< 98% RH, condensing
Vibrations	Lloyds Register, test 2

Note

{1} Configurable

EMC data

Immunity	EN 50082-2, EN 61326
Burst:	2 kV
RFI, shielded cable:	30 V/m
RFI, unshielded cable:	10 V/m
Emission	EN 50081-2, EN 61326

Approval (Demko) EEx ia IIC T5/T6, ATEX II 1G

Approval (BKI) Ex ia IIC T5/T6

Approval (Barbara) Ex ia IIC T5/T6

Supply range	6.5...30 V _{dc}
Internal inductivity	L _i ≤ 15 µH
Internal capacity	C _i ≤ 2 nF
Barrier data	U ≤ 30 V _{dc} ; I ≤ 0.1 A ; P ≤ 0.75 W
Temperature class	T1...T5: -40 < T _{amb} < 85°C T1...T6: -40 < T _{amb} < 50°C

Approval (Demko) Ex N IIC T5/T6

Temperature class	T1...T5: -40 < T _{amb} < 85°C T1...T6: -40 < T _{amb} < 50°C
--------------------------	--

Mechanical data

Dimensions	ø44 x 26.3 mm
Protection class	Housing: IP 55 Terminals: IP 10

Other data

Isolation	3.75 kV _{ac}
Temperature drift	Typ. 0.003% per °C Max. 0.01% per °C
Power-on time	1.8...3.9 sec.

Test conditions

Configuration	Pt100; 0...100°C
Amb. temperature	23°C +/- 2°C

Disposal of product and packing

According to national laws or by returning to Bourdon-Haenni

Example of Application, Point-to-Point

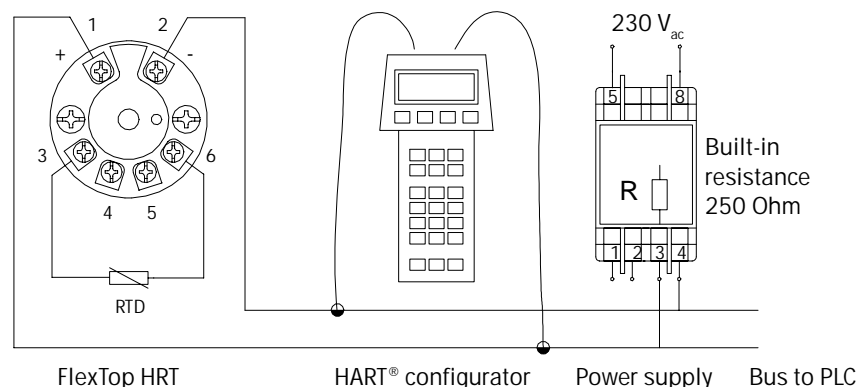

Measuring Ranges

Type	Standard	Range	Min. span	Accuracy	Resolution
Pt25...Pt1000	DIN/EN/IEC 60751	-200...850°C {2}	10°C	0.1°C	0.1°C
Pt25...Pt1000	a = 0.003902	-200...850°C {2}	10°C	0.1°C	0.1°C
Pt25...Pt1000	a = 0.003916	-200...850°C {2}	10°C	0.1°C	0.1°C
Ni25...Ni1000	DIN 43760	-50...250°C {2}	10°C	0.1°C	0.1°C
Cu25...Cu1000	0.428 Ohm/°C	-50...200°C	10°C	0.1°C	0.1°C
B(PtRh30-Pt)	IEC 584	100...1820°C	50°C	2°C	0.1°C
C(W5-Re)	ASTM 988	0...2300°C	100°C	2°C	0.1°C
D(W3-Re)	ASTM 988	0...2300°C	100°C	2°C	0.1°C
E(NiCr-CuNi)	IEC 584	-270...900°C	50°C	1°C	0.1°C
J(Fe-CuNi)	IEC 584	-210...1200°C	50°C	1°C	0.1°C
K(NiCr-Ni)	IEC 584	-250...1370°C	50°C	1°C	0.1°C
L(Fe-CuNi)	DIN 43710	-200...900°C	50°C	1°C	0.1°C
N(NiCrSi-NiSi)	IEC 584	-200...1300°C	50°C	1°C	0.1°C
R(PtRh13-Pt)	IEC 584	-50...1750°C	100°C	2°C	0.1°C
S(PtRh10-Pt)	IEC 584	-50...1750°C	100°C	2°C	0.1°C
T(Cu-CuNi)	IEC 584	-250...400°C	40°C	1°C	0.1°C
U(Cu-CuNi)	DIN 43710	-200...600°C	50°C	1°C	0.1°C
Lin. voltage		-10...70 mV	2 mV	0.04 mV	0.1 mV
Lin. voltage		-0.1...1.1 V	20 mV	0.4 mV	1 mV
Lin. resistance		0...390 Ohm	5 Ohm	0.05 Ohm	0.01 Ohm
Lin. resistance		0...2200 Ohm	25 Ohm	0.25 Ohm	0.1 Ohm

{2} The max. temperature is lower for RTD-elements in the range 500...1000, i.e. Pt1000 max. 350°C.

Configuration

Note:

Disconnect loop supply before connecting the FlexProgrammer to FlexTop HRT.

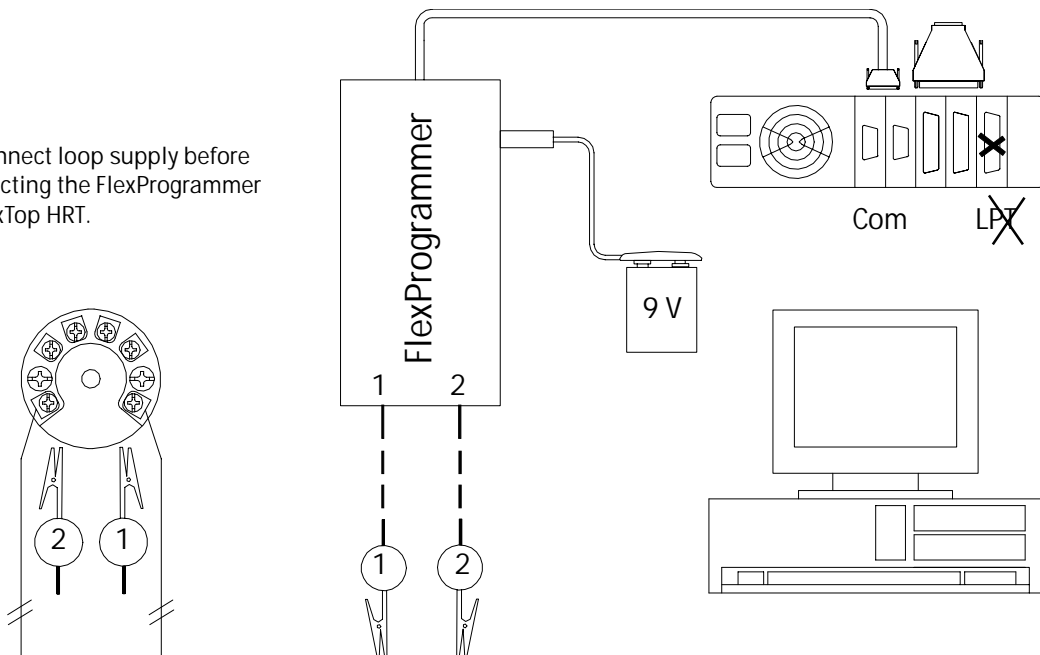

Ordering Details

FlexTop HRT

81 4x-72x

Type	
7	Standard version
8	Demko EEx ia IIC T5/T6, ATEX II 1G ; BKI Ex ia IIC T5/T6
9	Demko Ex N IIC T5/T6
A	Barbara Ex ia IIC T5/T6

Configuration

4	Not configured
5	Configured according to customer specifications

Electrical Installation

RTD	T/C	Potentiometer	Resistance
-----	-----	---------------	------------

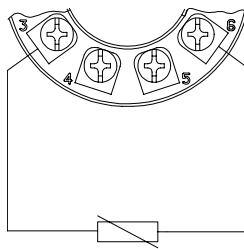

No cable compensation {3}

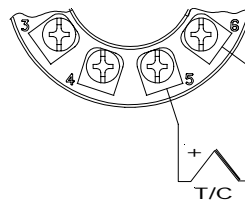

Internal CJC-compensation

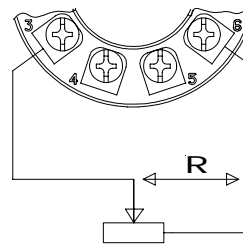

No compensation {3}

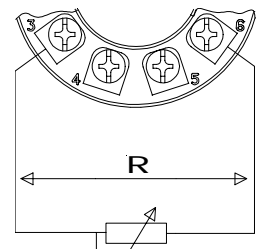

No compensation {3}

RTD	T/C	Potentiometer	Resistance
-----	-----	---------------	------------

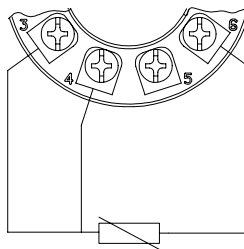

3-wire cable compensation

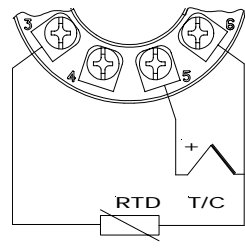

External CJC-compensation
No cable compensation {3}

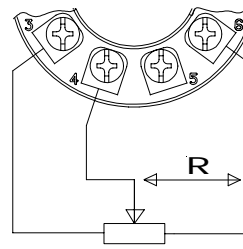

3-wire compensation for transfer resistance {4}

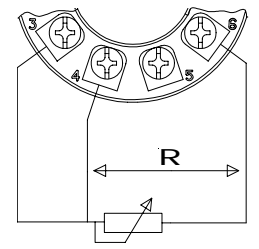

3-wire cable compensation

RTD	T/C	Potentiometer	Resistance
-----	-----	---------------	------------

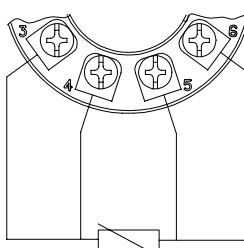

4-wire cable compensation

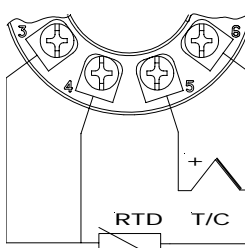

External CJC-compensation
3-wire cable compensation

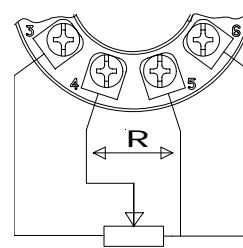

4-wire compensation for transfer resistance {4}

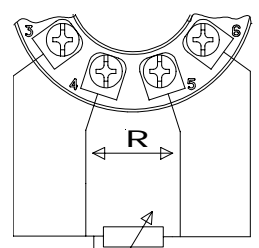

4-wire cable compensation

Current measurement	Voltage measurement	Notes
---------------------	---------------------	-------

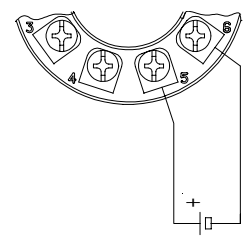
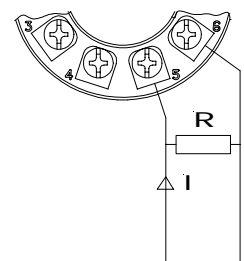

{3} Configurable compensation for cable resistance
{4} Transfer resistance between element and wiper

Dimensional drawing

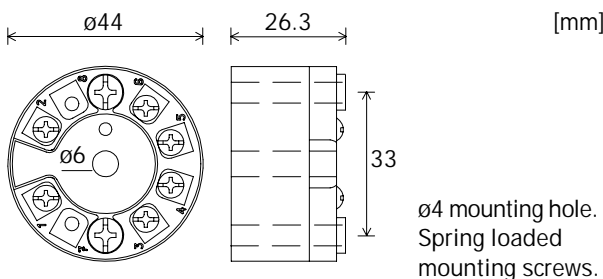

Accessories

FlexProgrammer configuration set, type number 82 23-903 comprises:
FlexProgrammer with 9 pole RS232C cable
3.5" Program diskettes
Battery plug
Cable with test plugs



2220-1-GB/2001-10-01 This data sheet may only be reproduced in full.