

MK and PK series

A wide range of hardware combination always equipped with all the special software functions make these instruments highly flexibles.

The use of a custom display able to get at a glance the complete process status together with internal and external software solutions make an easy configuration and assure an excellent operator interface.

General features

- The configuration software allows to simplify the instrument configuration, the run time parameter setting and the program construction.
- SDDE driver is a simple object oriented interface between ERO instruments and Windows® applications.

Windows® is a Microsoft Corporation registered trademark

- Three rows 4-digit LED display for an excellent operator interface.
- 2 bar-graph LED display (MKP and MKC).
- IP 65 and NEMA 4X front protection.
- Programmable digital filter on the measured value and on the retransmitted value.
- Open input circuit alarm.
- Control output security value.

Controllers (MKC - PKC)

- 4 digital outputs.
- 2 isolated mA outputs.
- Remote set point input + trim function.
- UL and cUL approved.

Programmers (MKP - PKP)

- Clock calendar function for the automatic start, daily or weekly, of a selectable program.
- 200 segments available.
- Up to 90 programs, each program can be composed by a different number of segments.
- Up to 9 linked programs (each one can encompass up to 9 independent programs).
- 5 PID parameters groups and 10 wait bands.
- Up to 14 break events are programmable for each segment.
- Up to 14 timer events selectable for each program.
- Up to 11 logic inputs and 14 digital outputs (relay, SSR, or servo).
- 2 isolated mA outputs.
- Output Power Off function.





MK and PK series

FRONT EXTRACTION

The design of some innovative mechanical solutions allows to make the instrument extraction particularly easy. In fact, it does not require any tool and the extraction force is very little whereas the front lock assures a safe and vibration resistant fixing.



CONFIGURATION

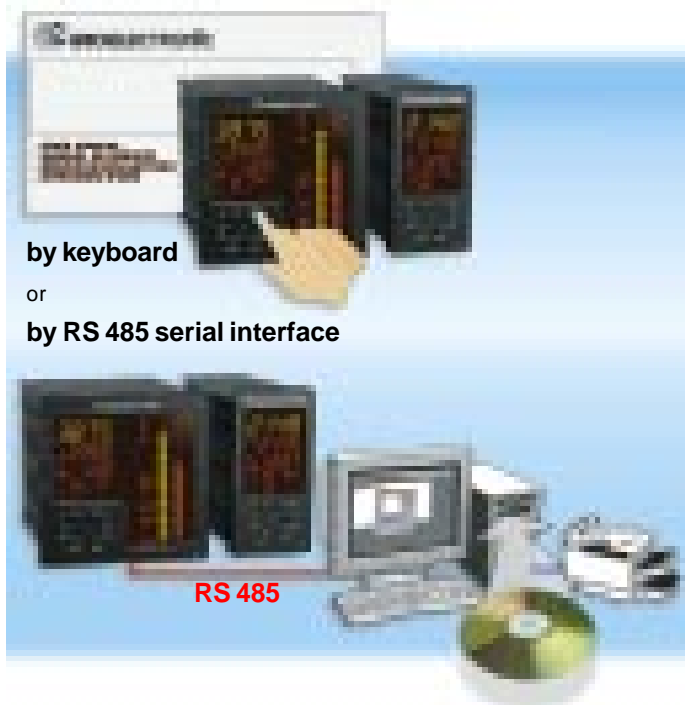

Configuration program

The configuration package is a special software developed to simplify instrument configuration, run time parameters setting and program construction. The capability to memorize a complete configuration set, offers a quick and reliable configuration system and deletes maintenance time loss. The capability to print a configuration report increases work traceability (as required by the Quality Systems) and simplifies plant analysis.

HOWTOORDER
configurator:
6ER.CNF.000.XXX

SDDE

DDE communication driver for ERO electronic devices

How can you simply create a dynamic link between ERO instruments and a PC running Windows®? Now it is quick and inexpensive by using SDDE driver developed by ERO Electronic to make available, as Windows objects, the process data handled by the instruments as well as there run-time and configuration parameters.

The integration of ERO instruments in the Windows work environment allows to link them to any Windows

based package like Excel, Word, etc., and simplifies the building up of your own application by using any other tool like In-Touch, Visual Basic and similar.

Windows® is a Microsoft Corporation trademark



HOW TO ORDER *communication driver:* 6ER.SDD.E00.XXX

MK and PK series

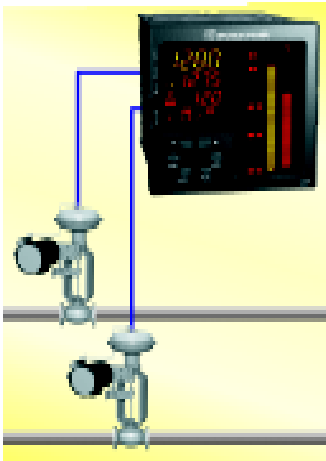

Split range of the output

This function allows you to drive two different physical outputs (two different actuators) with the same calculated output. The possibility to set different bias and gain for the two physical outputs gives:

- better control accuracy [ex. for a better flow control it is possible to use two small valves instead of a big one and set the instrument as in drawing (1)]
- energy saving possibilities (ex. for air ventilation it is advisable to drive only a part of the available fan and to drive the remaining one when the first part reaches the 100 % of its capability)

- a 3-segment output characteristics as shown by the drawing (2) [Special process]

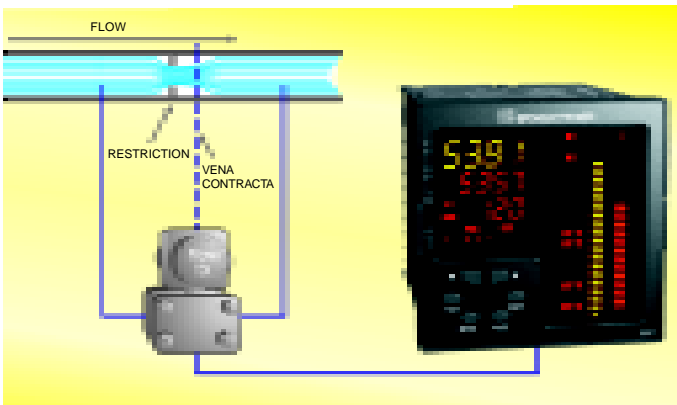
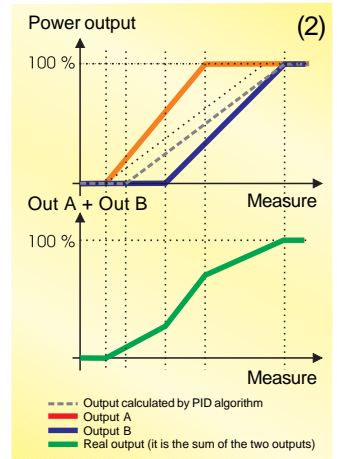
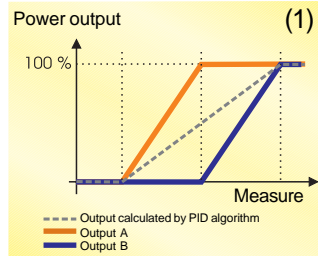

Square root extraction on the measured value.

These instruments offer the possibility to extract the square root of the measured value. This function allows to measure a flow with a standard DP transmitter and without any other apparatus.

Auxiliary power supply.

These instruments can be equipped with a non isolated auxiliary power supply able to simplify the connection with a 2, 3 or 4-wire transmitter.

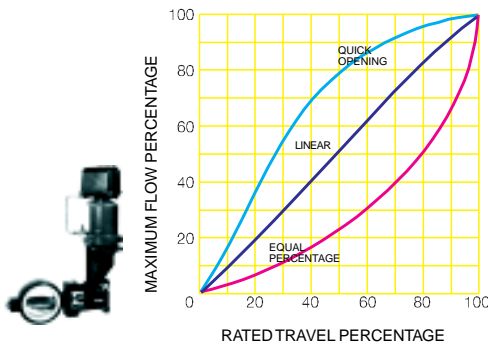

Preprogrammed output characteristics

This instrument allows to the user to select an output linearization in accordance with the two most common valve flow characteristics:

- Quick opening
- Equal percentage.

This function allows to linearize the ratio between flow rate and valve travel in order to obtain a better control of the process.

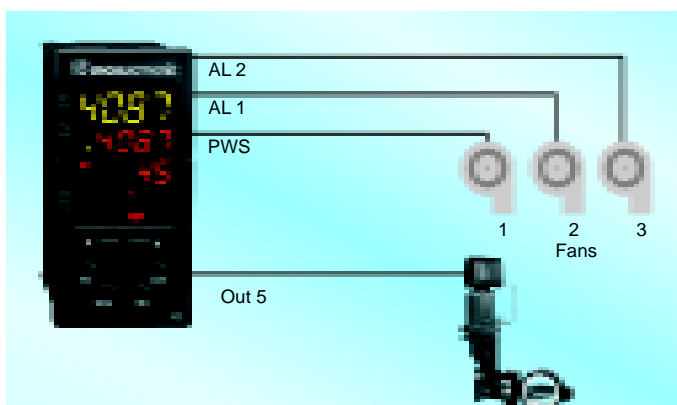

Alarm on the output values

This function allows to set alarm thresholds directly on the control output percentage of the instrument. This possibility simplifies the control of these process where it is necessary to generate an action related only with the control output percentage. Example: the instrument is controlling a process by driving an air flow valve. The air flow generator is composed of 3 fans; the first one is always ON while the second and third are turned ON when the power output reaches the programmed value [33 % (AL 1) and 66% (AL 2)].

This solution allows to reduce power consumption and improve control quality.

Power output

Out 5

Measure



GENERAL SPECIFICATIONS

Case:	Polycarbonate
Self extinguishing degree:	According to UL 746 C.
Front protection:	designed and tested for IP 65 and NEMA 4X for indoor locations (when panel gasket is installed). Test performed in accordance with IEC 529, CEI 70-1 and NEMA 250-1991 STD.
Installation:	panel mounting
Rear terminal board:	32 screw terminals for MKC, PKC and PKP (54 for MKP) with connection diagram and safety rear cover
Dimensions: (according to DIN 43700)	48 x 96 mm for PKP and PKC 96 x 96 mm for MKP and MKC Depth 128 mm.
Weight:	500 g for PKP and PKC 600 g for MKC 700 g for MKP.
Power supply: (switching type)	from 100 to 240 V AC 50/60 Hz (from +10% to -15% of the nominal value) or 24 V DC/AC ($\pm 10\%$ of the nominal value).
Power consumption:	15 VA max. for PKC 16 VA max. for MKC and PKP 20 VA max. for MKP
Insulation:	a double or reinforced insulation is guaranteed between the power supply and all the instrument inputs and outputs.
Common mode rejection ratio:	> 120 dB @ 50/60 Hz.
Normal mode rejection ratio:	> 60 dB @ 50/60 Hz.
Electromagnetic compatibility and safety requirements:	This instrument is marked CE. Therefore, it is conforming to council directives 89/336/EEC (reference harmonized standard EN 50081-2 and EN 50082-2) and to council directives 73/23/EEC and 93/68/EEC (reference harmonized standard EN 61010-1).
Resolution:	30000 counts.
Sampling time:	125 ms for linear inputs 250 ms for TC or RTD
Accuracy:	$\pm 0.2\%$ f.s.v., @ 25 °C and nominal power supply
Operating temperature:	from 0 to +50 °C
Storage temperature:	from -20 to +70 °C
Humidity:	from 20% to 85% RH not condensing.

MEASURING INPUT

All inputs are factory calibrated and selectable by front keyboard. It is possible to apply a first order digital filter on the displayed value. The time constant of the filter may be programmed within 0 and 8 seconds.

RTD input

RTD type:	Pt 100 3 wires connection
Calibration:	according to DIN 43760
Line resistance:	Max. 20 Ω /wire with no measurable error.
Burn out:	Detection of the sensor open circuit and of one or more wires open circuit. The instrument shows the short circuit indication when the sensor resistance is lower than 12 Ω .
Standard ranges:	from -200 to 850 °C or from -199.9 to 850.0 °C from -330 to 1560 °F or from -199.9 to 999.9 °F.

Thermocouples

Line resistance compensation error:	max. $\pm 0.1\%$ of input span with input impedance $\leq 100\Omega$.
Burn out:	Detection of the open input circuit (wire or sensor) with underrange or overrange selectable indication.
Cold junction compensation error:	automatic compensation for an ambient temperature between 0 and 50°C.
Cold junction compensation error:	0.1 °C/°C.
Input impedance:	> 1M Ω .
Calibration:	according to IEC 584-1.

STANDARD RANGES TABLE

TC type	°C	Range	°F
B	0 / 1820		+32 / 3300
C	0 / 2300		0 / 4170
D	0 / 2300		0 / 4170
E	-100 / 800		-150 / 1470
G	0 / 2300		0 / 4170
L	-100 / 900		-150 / 1650
J	-100 / 1000		-150 / 1830
K	-100 / 1370		-150 / 2500
N	-100 / 1400		-150 / 2550
Ni/NiMo	0 / 1100		0 / 2000
R	-50 / 1760		-60 / 3200
S	-50 / 1760		-60 / 3200
T	-200 / 400		-330 / 750
U	-200 / 600		-330 / 1110

MK and PK series

Linear inputs (mA and V)

Input linearization: programmable square root extraction.
Readout: keyboard programmable from -1999 to 9999.
Decimal figure: programmable in any position.

STANDARD RANGES TABLE

Input		Impedance	
0 - 20	mA	5	Ω
4 - 20	mA	5	Ω
0 - 60	mV	> 1	M Ω
12 - 60	mV	> 1	M Ω
0 - 5	V	> 200	k Ω
1 - 5	V	> 200	k Ω
0 - 10	V	> 400	k Ω
2 - 10	V	> 400	k Ω

Auxiliary input (optional)

Function: for MKP - PKP this input can be used as trim function, algebraically added between this value and the operative set point. for MKC - PKC this input can be used as trim function, or as remote set point input.

Type: not isolated

Scaling: programmable from -1999 to 9999, the decimal figure is automatically positioned as for main input.

Sampling time: 500 ms.

Accuracy: $\pm 0.2\%$ f.s.v.
 ± 1 digit @ 25 °C and nominal power supply voltage.

Temperature drift: 300 ppm/°C.

STANDARD RANGES TABLE

Input		Impedance	
0 - 20	mA	5	Ω
4 - 20	mA	5	Ω
0 - 5	V	> 200	k Ω
1 - 5	V	> 200	k Ω
0 - 10	V	> 400	k Ω
2 - 10	V	> 400	k Ω

OUTPUTS

Types: these products may be supplied with up to 4 digital outputs (relè, SSR, TRIAC or servomotor drive) and up to 2 linear outputs (mA).

Digital outputs OUT 1 and 2

Function: singularly programmed as:
 - control output
 - alarm output
 - event output.

Type: relay, SSR or TRIAC.

OUT 1 and 2 - Relay

Relay type: SPDT
Contact rating: 3 A @ 250 V A.C. on resistive load.

OUT 1 and 2 - SSR

Type: not isolated voltage outputs.
 - Logic level 1: 14 V @ 20 mA max. 24 V @ 1 mA.
 - Logic level 0: < 0.5 V c.c.

OUT 1 and 2 - TRIAC

Switching mode: isolated zero crossing type.
Triac rating: from 50 mA to 1 A
 from 24 V_{rms} to 250 V_{rms}

OUT 3 and 4

Function: singularly programmed as:
 - control output
 - alarm output
 - event output.
 - Servomotor drive (OUT 3 open, OUT 4 close).

Type: relay SPST.

Contact rating: 3 A @ 250 V A.C. on resistive load. The OUT 3 and 4 commons are connected together with the same rear terminal.

Servomotor output

Type: two relays interlocked (OUT 3 and 4).

Servomotor output type:
 - Close loop
 - Open loop with valve position indication only.
 - Open loop without valve position indication.

Feedback potentiometer input: from 100 Ω to 10 k Ω .

Servomotor travel time: from 12 seconds to 3 minutes.

Servomotor dead band: from 1% to 50% of the feedback span or of the valve travel time.



Analog outputs OUT 5 and 6

Function:	programmable as - Control output - Analog retransmission of the measured value - Analog retransmission of the operative set point.
Output type:	Isolated output programmable as: 0-20 mA 4-20 mA.
Scaling:	programmable from -1999 to 9999.
Maximum load:	600 Ω.
Accuracy:	0.1% when it is used as control output. 0.05% when it is used as analog retransmission.
Filter:	it is possible to apply a first order digital filter on the retransmitted value. The time constant of the filter may be programmed within 0 and 8 seconds.

CONTROL ACTION

Algorithm:	PID + SMART
Types:	- one control output (digital or analog output) - one control output splitted on two outputs (split range). - two control outputs. The outputs can be freely selected among analog, digital or servo.
Digital output types:	relay, SSR or TRIAC.
Digital output control action:	proportional time
Analog output types:	linear (20 mA).
Servomotor output:	Two relays interlocked.
Proportional band:	programmable from 0.5% to 999.0% of the input span. Setting a PB equal to 0 the control action becomes ON/OFF.
Hysteresis (for ON/OFF control action):	programmable from 0.1% to 10.0% of the input span.
Integral time:	programmable from 1 second to 20 minutes or excluded.
Derivative time:	programmable from 1 second to 10 minutes or excluded.
Integral preload:	programmable - for one control output, from 0 to 100% of the output range. - for two control outputs, from -100% to +100% of the heating/cooling output range.
Main output cycle time:	from 1 second to 200 seconds.
Secondary output cycle time:	from 1 second to 200 seconds
Relative secondary output gain:	programmable from 0.20 to 2.00 referred to proportional band.
Overlap/dead band:	programmable from -20% (dead band) to +50% (overlap) of the proportional band.
Output limiters:	for main and/or secondary control outputs it is possible to set: - output high limits - output low limits - output max. rate of rise.
AUTO/MANUAL mode:	selectable by front pushbutton or logic input.

ALARMS

Alarm action:	Direct or reverse function programmable.
Alarm functions:	each alarm can be configured as process alarm, band alarm, deviation alarm or process alarm on the output value.
Alarm reset:	Automatic or manual reset programmable for each alarm.
Alarm masking:	each alarm can be configured as masked alarm or standard alarm. This function allows to delete not desired alarm indications at instrument start up and after a set point changement.

Process alarm

Operative mode:	minimum or maximum programmable.
Threshold:	programmable in engineering units within input range.
Hysteresis:	programmable in engineering units from 1 to 200 digits.

Band alarm

Operative mode:	inside or outside programmable.
Threshold:	two thresholds are programmable: low - from 0 to -1000 units. high - from 0 to +1000 units.
Hysteresis:	programmable in engineering units from 1 to 200 digits.

Deviation alarm

Operative mode:	high or low programmable.
Soglia:	programmable from -1000 to +1000 units.
Hysteresis:	programmable in engineering units from 1 to 200 digits.

MK and PK series

Alarm on the main output values

It is possible to obtain an alarm condition when the main control output is lower or higher than a programmed value.

Operative mode: minimum or maximum programmable.
threshold: programmable from 0.1 to 100.0% of the output.
Hysteresis: programmable in engineering units from 0.1 to 20.0% of the output.

Alarm on the secondary output values

It is possible to obtain an alarm condition when the secondary control output is lower or higher than a programmed value.

Operative mode: minimum or maximum programmable.
threshold: programmable from 0.1 to 100.0% of the output.
Hysteresis: programmable in engineering units from 0.1 to 20.0% of the output.

Output failure detection (OFD function) (optional)

The instruments equipped with this feature are capable to measuring, by means of a CT, the running current of one control output.

- During the ON period of the output, the instrument measures the current through the load and it generates an alarm condition when this current is lower than a pre-programmed threshold value (a low current shows a partial or total break down of the load or of the actuator).
- During the OFF period of the output, the instrument measures the leakage current through the load and it generates an alarm condition when this current is higher than a pre-programmed threshold value (a high leakage current shows a short circuit of the actuator).

Input range: 50 mA AC.
Scaling: programmable from 10 A to 100 A (with 1A step).
Resolution:
 - For full scale up to 20A : 0,1A
 - For full scale from 21 A to 100 A: 1A
Active period:
 - For relay output: NO or NC programmable.
 - For SSR output: logic level 1 or 0.
Minimum active period to perform the measurement: 120 ms.
 This function is applicable only to a control output programmed as proportional time output (relay or SSR)

Serial interface (optional)

Type: RS 485 isolated.
Protocol type: MODBUS, JBUS.
Baud rate: programmable from 600 to 19200 BAUD.
Byte format: 8 bit.
Parity: even, odd or none programmable.
Stop bit: one.
Address: from 1 to 255.
Output voltage levels: According to EIA standard.

Auxiliary power supply (Optional)

Type: 24 V DC \pm 20% not isolated.
Max. current: 25 mA.





MKP and PKP programmers

PROGRAMMER

Program flexibility

These instruments allow to create programs with different number of segments. For example, 4 programs are created.

The program N° 1 is composed by 9 segments.

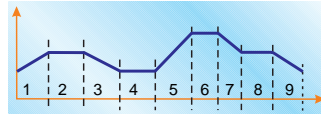

The program N° 22 is composed by 4 segments.

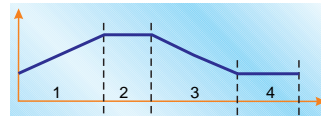

The program N° 8 is composed by 15 segments.

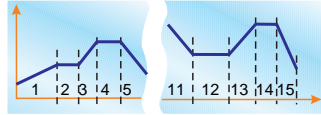

The program N° 45 is composed by 67 segments.

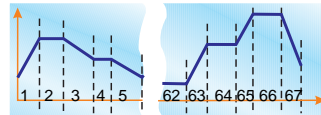

The 105 remaining segments (95 of 200 are used) can be used to create new programs or to modify the already existing one's.

Linked programs

Right side is shown a linked program (L1). It is formed of 3 single programs (7, 20 e 5). If a difference between the final set point of a program (A) and the initial set point of the next program (B) occurs; the wait function will guarantee the correct execution of the first segment of the next program (C).

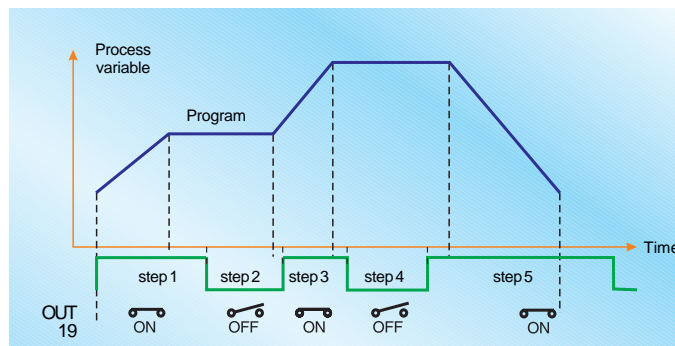
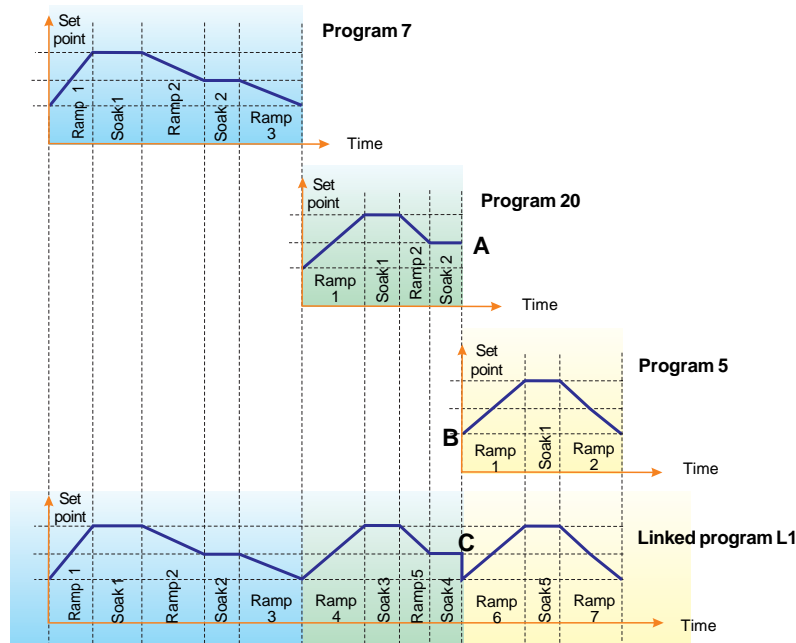

Timer events

This function allows to associate to a program one or more outputs selected as timer event (ex. OUT 19).

These timers are synchronized to the program starting and each one of them is composed of 5 steps maximum and they are independent of the program profile.

Each step is associated to an output state, as shown in the example, and it is programmable from 1 second to 99 hours and 59 minutes.

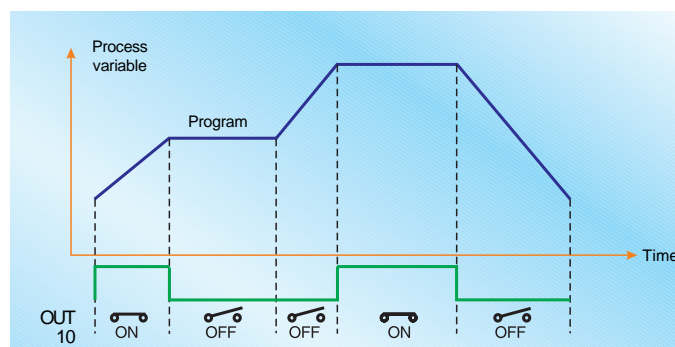

Break events

With this function it is possible to associate to each segment the state ON or OFF of one or more outputs selected as break event (ex. OUT 10).

MKP and PKP programmers

PROGRAMMERS SPECIFICATIONS

SEGMENTS

Up to 200 segments are available.

For each segment is possible to:

- set its duration in hours and minutes (up to 99 h and 59 m) or in minutes and seconds (up to 99 m and 59 s);
- relate to a group of PID parameters chosen among 5;
- relate to a wait band chosen among 10;
- relate to one or more break event.

SIMPLE PROGRAMS

Up to 90 simple programs are available.

For each simple program it is possible to:

- use a different number of segments up to 99;
- set the program repetitions;
- set the instrument behaviour after the last programmed cycle is carried out;
- relate to up to 14 timer events;
- relate to an end of cycle indication;
- relate to an end of profile indication;

LINKED PROGRAMS

Up to 9 linked programs are available.

- each linked program can include up to 9 simple programs.

FUNCTIONS AVAILABLE when a program is in progress

- EDIT** The Edit mode allows to create, to modify or to delete programs.
- WAIT** This function keep automatically frozen the progress of the operating program if the process value is outside the wait band. The progress of the program will automatically restart when the process value will return inside the wait band.
- HOLD** By this function it is possible to temporarily stop the operating program.
- ABORT** By this function the operating program is aborted, the instrument reverts to Edit mode.
- FAST** This function allows to reach, 60 times faster than the normal speed, a particular point of the profile, forward or backward, from where it is desired to restart the program.
- JUMP** By this function it is possible to jump from the operating segment to the beginning of the next or the previous segments.

PROGRAM SELECTION BY LOGIC INPUTS

This function allows to select by an external device (ex. PLC) the operating program acting through logic inputs.

Each logic input used for the program selection is related to a weight of binary code.

In the example below, the logic inputs Dig 2, In 1 and In 4 are used for program selection.

Programs	Input	Weight	Input	Weight	Input	Weight
	Dig 2	2 ⁰	In 1	2 ¹	In 4	2 ²
1	On		Off		Off	
2	Off		On		Off	
3	On		On		Off	
4	Off		Off		On	
5	On		Off		On	
6	Off		On		On	
7	On		On		On	

END OF CYCLE AND END OF PROFILE FUNCTIONS

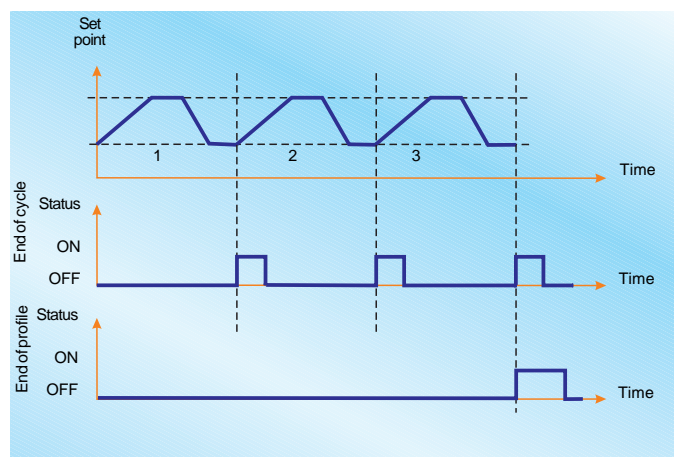

This example shows a program formed by 4 segments and it is repeated for 3 times.

END OF CYCLE

This function allows to automatically get an indication, by a digital output, whenever a program cycle is ended. The status (ON or OFF) of the output and its duration can be programmed.

END OF PROFILE

This function allows to automatically get an indication, by a digital output, whenever a profile is ended. The status (ON or OFF) of the output and its duration can be programmed.



MKP and PKP programmers

SPECIAL FUNCTIONS

Clock calendar (Optional)



By this function, the operator presence is not required to start the operating program.

For the automatic starting it is possible to set:

- 1) the day of the week selected among:
 - one day only (monday, tuesday, etc..)
 - daily
 - daily without sunday
 - daily without saturday and sunday

- 2) the starting time

- 3) the operating program.

A lithium battery assures to the internal clock the correct working (even when the instrument power supply is OFF) for more than 10 years.

Output Power OFF

This operative mode simplifies the process management where zone switches or any other device to disable the process control are used.

This function disables the control outputs, the retransmissions, the alarms and the control algorithm at the same time.

In this mode, the instrument operates as an indicator and the process variable can be checked out even if the system is OFF or the zone is disabled.

When power up is resumed, the instrument sets to zero the integral action of the control signal and enables the soft start and alarm masking functions.

This function is particularly advantageous used in combination with the clock calendar function.

For example, by using a relay as output power OFF annunciator, it is possible to turn OFF the system (manually or automatically) and turn it ON automatically when the time programmed by clock calendar function is reached.

When the system is turned ON, the instrument starts the execution of the selected program and also activates all functions used at start up (soft start and alarm masking).

Additional outputs (optional)

For the MKP only, 5 + 5 digital outputs are available.

Function: singularly programmable as event output

Type: Relay type SPST.

Contact rating: 0.5 A @ 250 V AC on resistive load.

Note: The C side of all relays is connected in common.

Events

All the digital outputs can be programmed as events.

It is possible to set an event choosing among the following types:

- Break event
- Timer event
- End of cycle annunciator
- End of profile annunciator
- Program run annunciator
- Program wait annunciator
- Output Power OFF mode annunciator
- Error condition on the main input (overrange, underrange, open or short circuit).
- Error condition on both measuring inputs.
- Auto/Manual mode annunciator.

Logic inputs

Function: these instruments are supplied with 3 standard logic inputs, programmable as:

- auto/manual selection
- output limiter activation
- manual reset of alarm (acknowledgement)
- reverse/direct control action
- run/hold program selection(level or transition programmable).
- program selection
- program abort

Input type: contact closure (voltage free)

Active contact status: close or open programmable

Additional inputs (optional)

For the MKP only 4 + 4 logic inputs are available.

Function: Each additional logic input can be programmed as:

- run/hold program selection (level or transition programmable)
- program selection
- program abort

Input type: contact closure (voltage free).

Active contact status: close or open programmable.



MKP and PKP programmers

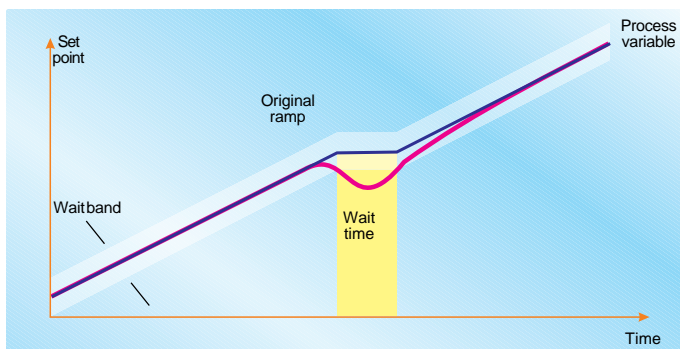

Wait and guaranteed soak functions

Up to 10 wait bands (each band is formed of the above and the below values) are available to correctly carry out ramps and soaks. Each segment may have different wait bands.

Wait function

If the process variable is outside the programmed wait band, the ramp in progress will be stopped; it will be restarted when the process variable will be returned inside the wait band.

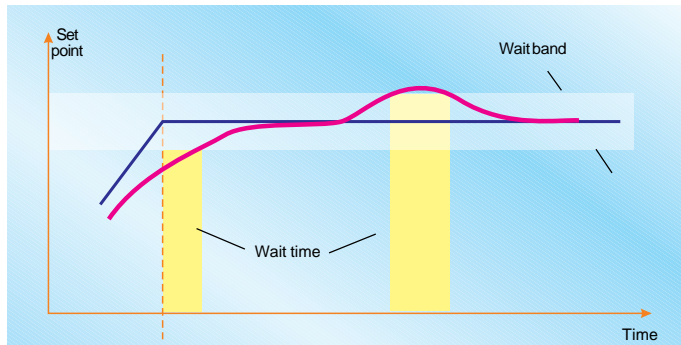

Guaranteed soak function

This function assures that, during a soak, the material is maintained at the temperature set for the entire programmed time. If the process variable is outside the programmed wait band, the soak time count will be stopped, it will restart when the process variable will be returned inside the wait band.

MKC and PKC controllers

CONTROLLERS SPECIFICATIONS

Set points

These instruments are supplied with 4 local set points (selectable by external contact) and an input for the remote set point (RSP).

The transfer from one set point to another may be done by a step transfer or by a ramp with two different programmable rates of rise (ramp up and ramp down)

Set point limiters: set point low limit and set point high limit programmable.

Rate of change for set point variations: from 1 to 200 digits per minute or excluded.

Digital filter: it is possible to apply a first order digital filter on the measured value by the remote set point input (RSP).

The time constant of this filter may be programmed within 0 and 8 s.

Remote set point input (optional)

The remote set point input may be programmed as trim function also (in this case, the remote set point value will be algebraically added to the selected set point value, the result will be used as operative set point).

Type: not isolated.

Scaling: programmable from -1999 to 9999, the decimal figure will be automatically positioned as for main input.

Sampling time: 500 ms.

Accuracy: $\pm 0.2\%$ f.s.v.
 ± 1 digit @ 25 °C and nominal power supply.

Temperature drift: 300 ppm/°C.

STANDARD RANGES TABLE

Input	Impedance
0 - 20 mA	5 Ω
4 - 20 mA	5 Ω
0 - 5 V	> 200 k Ω
1 - 5 V	> 200 k Ω
0 - 10 V	> 400 k Ω
2 - 10 V	> 400 k Ω

Events

All the digital outputs can be programmed as events.

It is possible to set an event choosing among the following types:

- Error condition on the main input (overrange, underrange, open or short circuit).
- Error condition on the remote set point input (RSP).
- Error condition on both measuring inputs.
- Auto/Manual mode annunciator.
- Local/remote set point annunciator.



MKC and PKC controllers

Logic inputs (optional)

Function: these instruments may be supplied with 3 logic inputs, each one can be programmed as:

- Set point selection (SP-SP2).
- Set point selection (SP3-SP4).
- Local/remote set point selection.
- Auto/manual mode selection.
- Output limiter activation.
- Data Hold of the measured value.
- Manual reset of alarms (acknowledgement)
- Direct/reverse control action.

Input type: contact closure (voltage free).

Active contact status: close or open programmable.

HOLD function

By an external contact it is possible to stop the input sampling keeping the last measured value frozen.

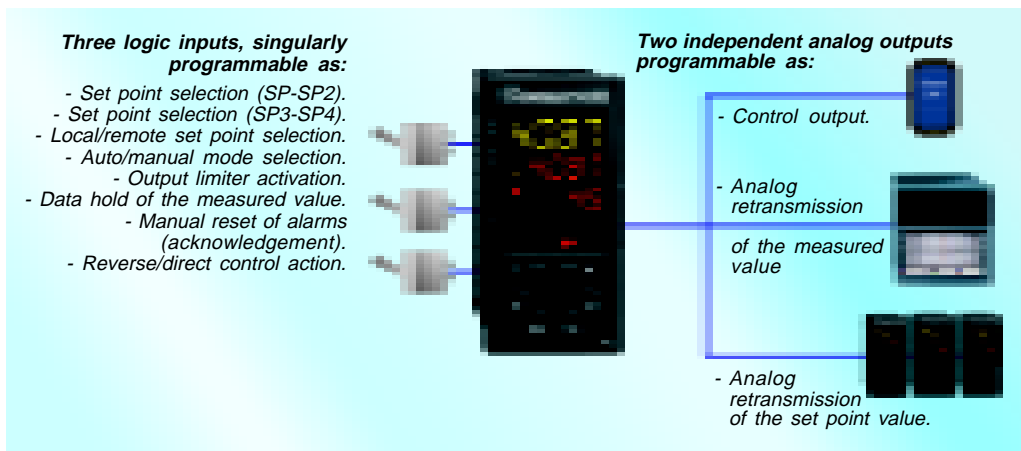

Output

Programmable output level limiter

Programmable output maximum rate of change

Time

Start up
Programmable time duration of the output level limiting

Set point

Two independent programmable ramps (ramp up and ramp down) for set point change

Time

First set point change

Second set point change

Readout

Programmable constant offset

Adjusted curve

Real curve

Measure

Soft Start function

This function allows to gradually pre-heat the controlled process in order to increase the heater life and to avoid thermal shock.

In order to use this function, it is necessary to program the level of power output to be used during pre-heating and its time duration.

The alarm masking function assures that no false indication will occur during pre-heating.

With these instruments is also possible to set the output power maximum rate of change in order to avoid thermal shock during normal operation.

Two independent ramps (ramp up and ramp down) for set point changes

These products allow to set a ramp for increasing a set point and a ramp for decreasing set point.

This solution is essential where it is necessary to produce a gradual set point variation.

Moreover, a process may need an heating speed different from cooling.

OFFSET on the measured value

These instruments offer the possibility to set a constant offset applied to the measured value in order to re-align the measured value with the real value of the process.

Ex. In many cases it is quite difficult to place the sensor in an ideal position.

The incorrect positioning of the sensor may produce a measured value that is not a true representation of the process value.

MK and PK series

HOW TO ORDER THE MKC - PKC

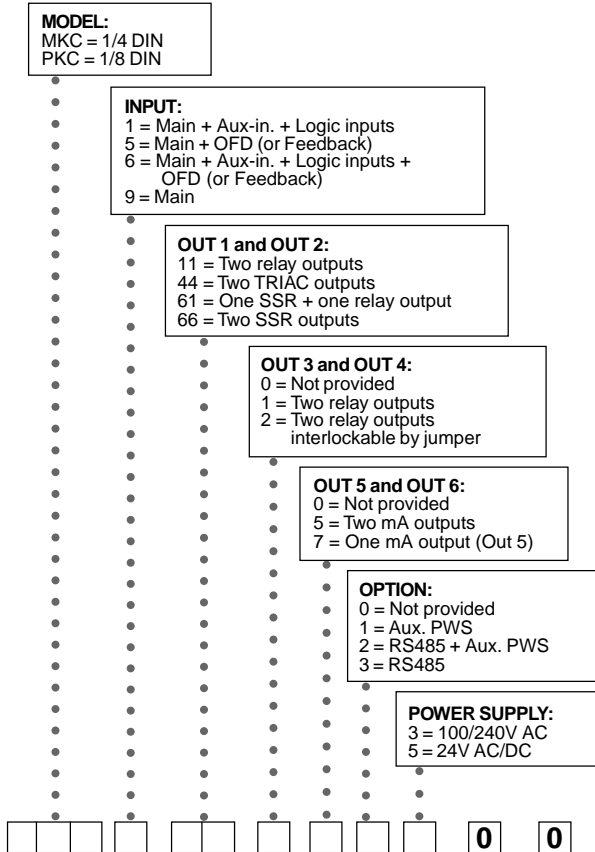

Optional ACCESSORY

CURRENT TRANSFORMER for instruments with OFD option

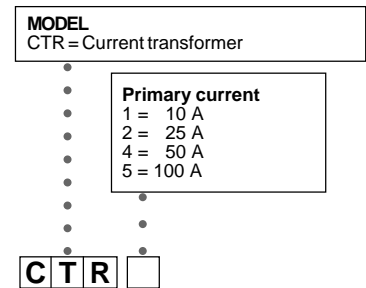

HOW TO ORDER THE MKP - PKP

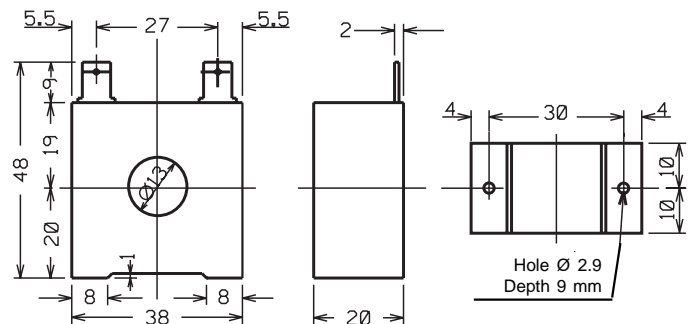
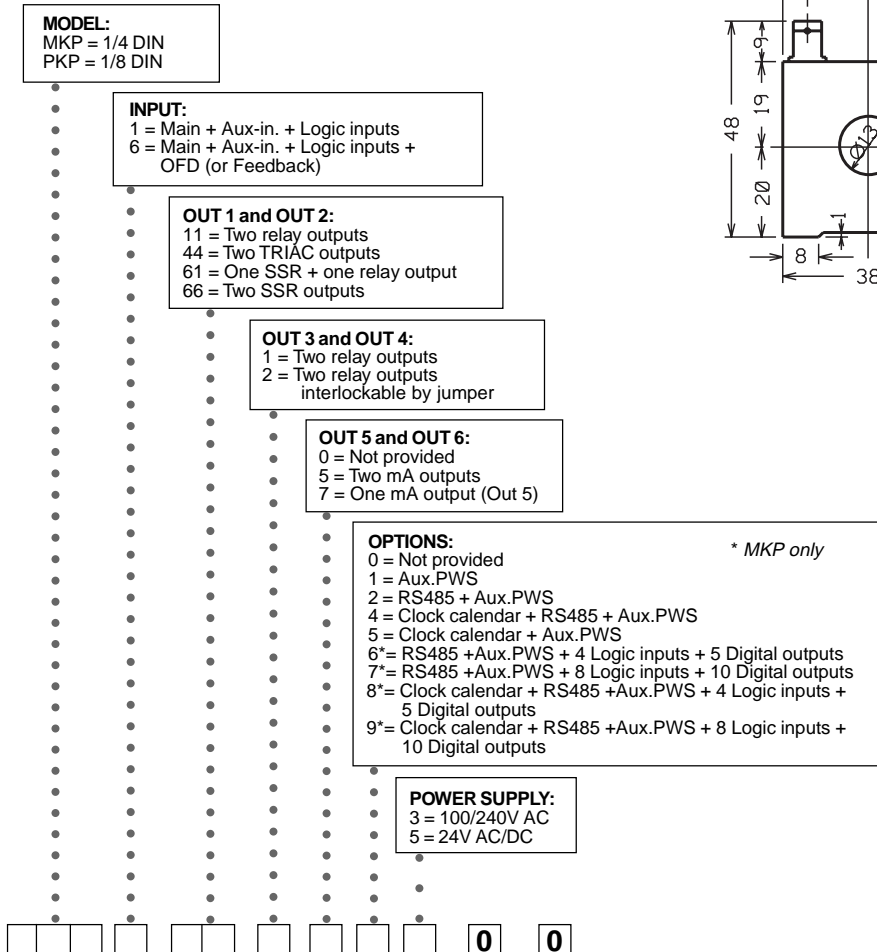



MK DIMENSION, PANEL CUT OUT AND CONNECTION DIAGRAM

(MKP ONLY)

PK DIMENSION, PANEL CUT OUT AND CONNECTION DIAGRAM

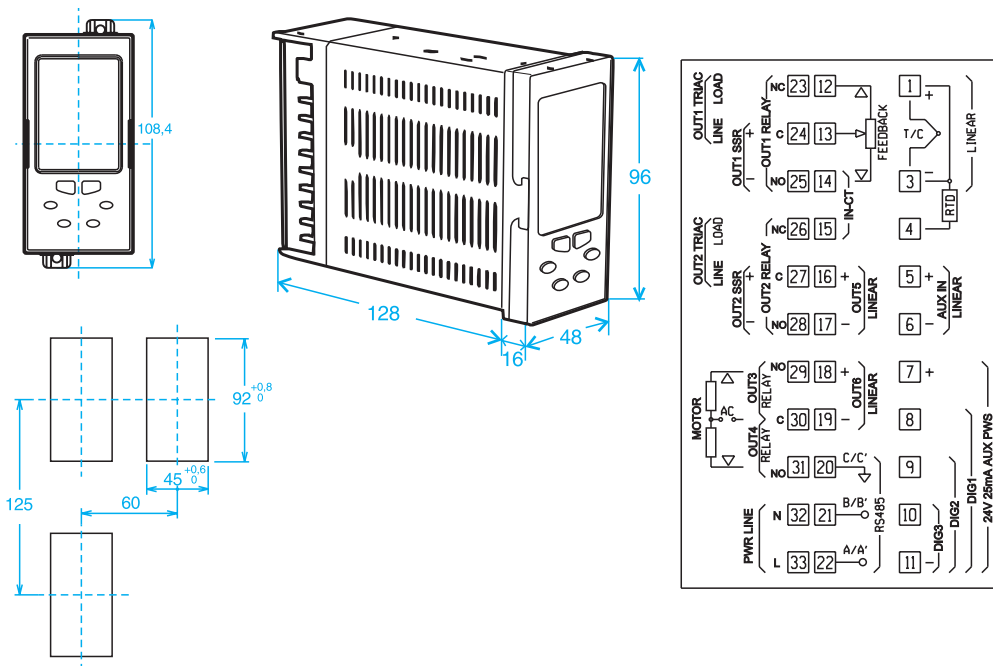

REAR PROTECTION

Particular care has been dedicated to the safety rear cover design. The used system assures an easy access to the terminals and it reports a clear description of the connection diagrams without to permit the protection removing.

